



**Product Description**

The NDI-225-FB is a 225 kV, water cooled stationary anode metal ceramic X-ray source. This source is specifically designed for Non-Destructive Imaging Applications.

**X-Ray Tube Specifications**

Maximum Peak Voltage .....	225 kV
Focal Spot EN12543 Large .....	D = 5.5 mm
Maximum Continuous Rating Large .....	3000 W with 4 Litre/min cooling flow
Temperature at fluid inlet (maximum) .....	35°C
Target Angle .....	20°
Cooling Medium .....	Water
Reference Axis .....	Perpendicular to port face.
Radiation Coverage .....	90° x 30°
Loading Factors for Leakage Radiation .....	225 kV, 13.0 mA
X-Ray Tube Assembly Permanent Filtration .....	1.0 mm Cu
High Voltage Cable .....	R24
Weight (approx.) .....	10.5 kg (23.1 lbs)

### **Instructions for Installation**

#### **Connection of the x-ray tube**

The careful adjustment of the pressure gap and the use of the correct amount of silicone grease are extremely important. First, clean the rubber cone carefully with a lint-free cloth. Take specific care that the contacts are absolutely free of old grease or oxide layers. Use only pure alcohol for cleaning, no other detergents. Cover the entire cone with a thin film of the supplied silicone grease, apply a rope of approximately 3 cm of grease and spread it gently, avoiding the contact tip. The grease layer must be kept free of air bubbles, dust or dirt.

#### **Cable terminal with mounting flange**

Rotate the mounting flange until there is a gap of 3-4 mm between the mounting flange and the tube. Remove the cable plug and carefully grease using the supplied high voltage insulating compound. Introduce the greased terminal plug parallel to the axis of the high voltage receptacle socket and advance until it stops.

#### **Mounting flange**

Attach the mounting flange to the tube housing using the flange fastening screws making sure not to rotate the mounting flange from its setup position.

### **Operation**

#### **General**

The control of the high voltage and the filament current as well as the design of the cooling unit is the responsibility of the equipment manufacturer.

#### **High Voltage Connection**

One terminal type R24 high voltage cables supply high voltage and filament current.

Two different methods of mounting the high voltage cable are available.

#### **Cooling of the Anode**

It is the responsibility of the customer to ensure that the cooling medium flow meets the required cooling conditions. Insufficient cooling of the anode can lead to the destruction of the anode, therefore cooling must be switched on before the application of high voltage.

#### **Control of Cooling Medium**

Flow, pressure, and temperature of the cooling medium at the inlet to the tube or the tube assembly must be appropriately monitored. High voltage must be terminated when the pressure or flow rate fall below the minimum level or when the temperature exceeds the maximum level. When the tube is switched off the coolant flow must continue for at least 2 minutes in order to protect the anode from destruction.

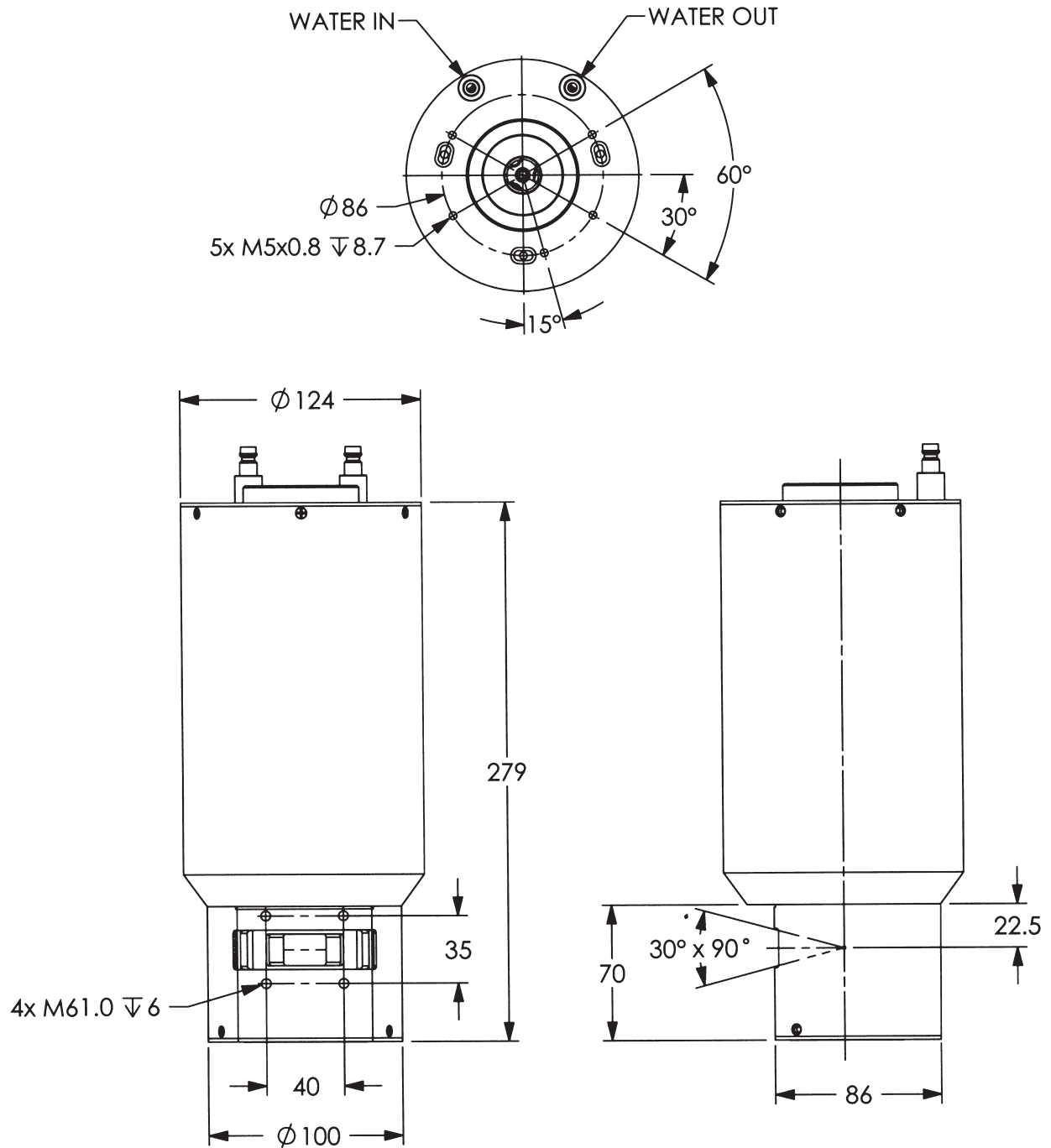

**3000 Watts**

