

Specification

Envelope Ceramic

Be Window 75 μm (0.0030”) Thick

Anode Copper body with the target material attached

Standard Target Materials Palladium-Cobalt

Target Angle 90° from the central ray

Focal Spot Typical 1.0 mm

Maximum Anode Dissipation with 10 cfm forced air cooling 50 Watts

Filament Characteristics 3.3 Amps and 2.5 Volts maximum

Maximum Anode Potential 50 kV

Maximum Tube Current Refer to Emission and Rating Chart

Cooling Method Forced air convection

Weight 2.7 lbs (1.23 kg)

DC EMISSION CHART

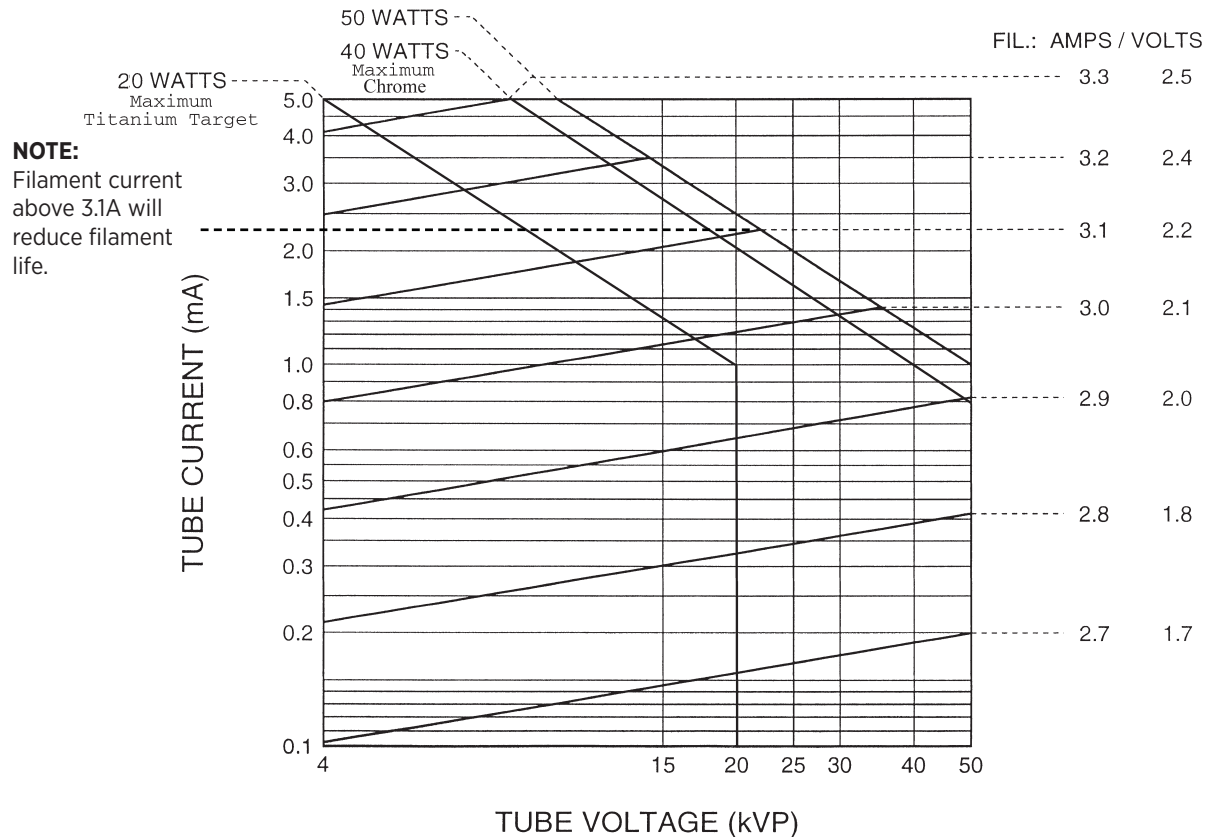

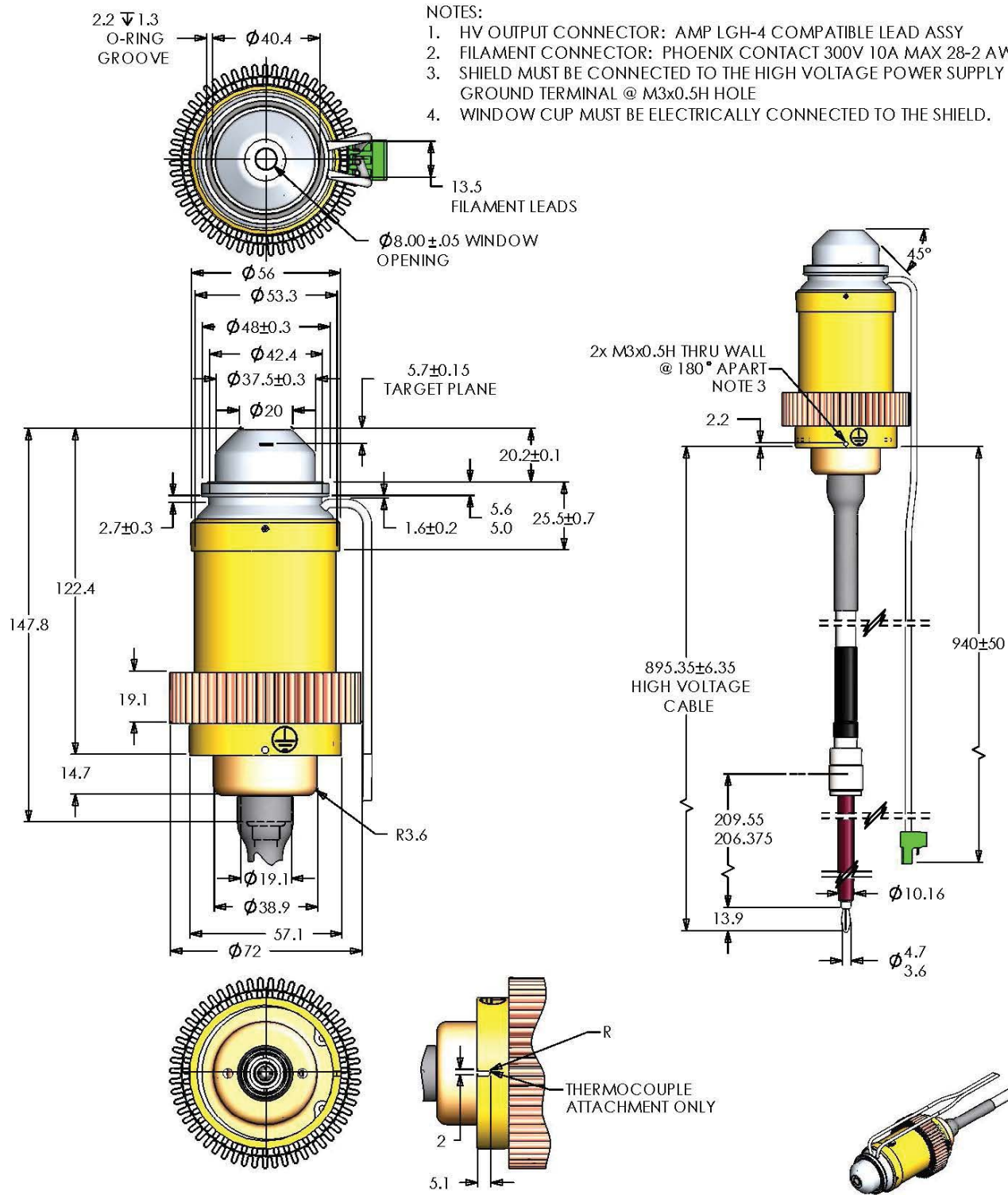

Reference A	
850 mm	120253

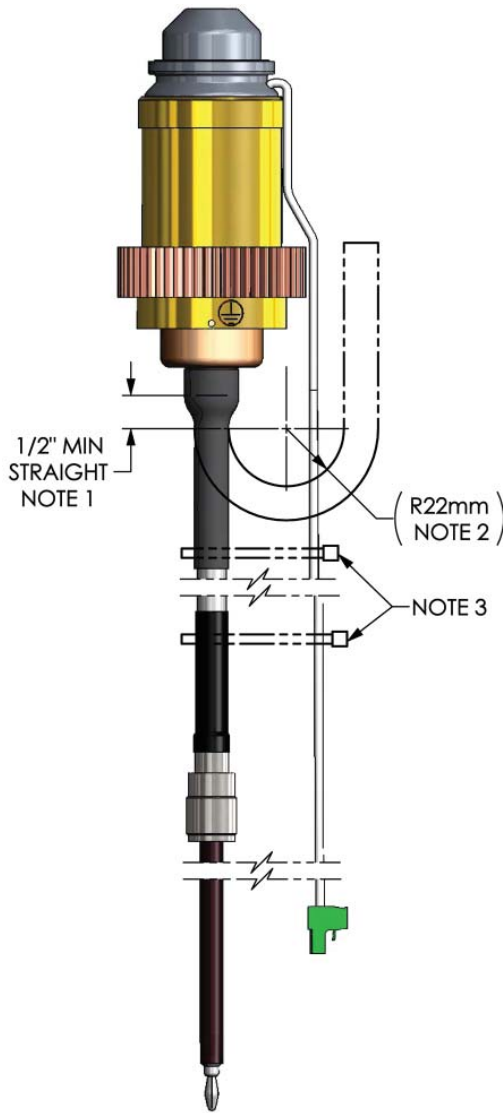

BAD EXAMPLE - DETAIL

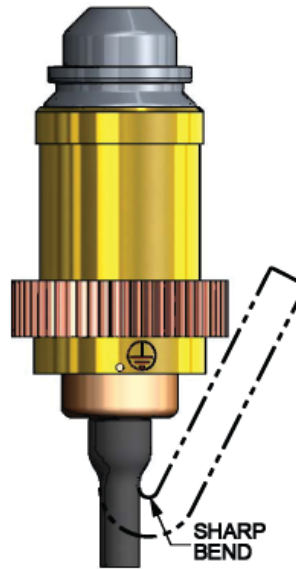

Notes:

1. The exit of the high voltage cable from the shield cup must not be bent for 1/2" from the exit. Bad example - details illustrates a poor example of routing of the cable at the shield cup exit.
2. The minimum bent radius of the high voltage cable is 22 mm.
3. The High Voltage cable should not be compressed by cable tie or instrument enclosures. If filament wires need to be routed with the high voltage cable, do not use the cable tie guns to install cable ties. Finger tightening the cable tie is recommended.

 **Warning**

Beryllium windows transmit a very high level of long wavelength X-radiation, which can injure human tissue. Injury may occur from even very short exposures to the primary X-ray beam. Follow all precautions necessary to avoid radiation exposure to humans.

The radiation dose rate cannot be accurately measured with conventional radiation measurement instruments. Radiation intensity in each installation will vary, and calibration must include the effects of long wavelength X-radiation.

Fumes from beryllium metal (or its compounds) as well as dust can be hazardous if inhaled. During use, corrosion products may occur on the beryllium window, but these should not be scraped off, machined, or otherwise removed. Tube unit disposal should conform to federal, state, and local regulations governing beryllium.