

**Specification**

Envelope .....	Ceramic	Filament Characteristics .....	3.1 Amps and 2.5 Volts maximum
Be Window .....	75 $\mu$ m (0.0030") Thick	Maximum Anode Potential .....	80 kVp Maximum DC
Anode .....	Copper body with the target material attached	Maximum Tube Current .....	4 mA @ 25 kV (Refer to Emission and Rating Chart)
Standard Target Materials .....	Rhodium, Palladium, Tungsten, Moly	Cooling Method .....	Forced air convection
Target Angle .....	90° from the central ray	Weight (with 1 meter cable) .....	5.1 lbs (2.3 kg)
Focal Spot Typical .....	1.0 mm	Fan .....	24 VDC
Maximum Anode Dissipation with forced air cooling @ 40°C maximum inlet air .....	100 Watts	Thermistor (B57045K) .....	6.8 k $\Omega$

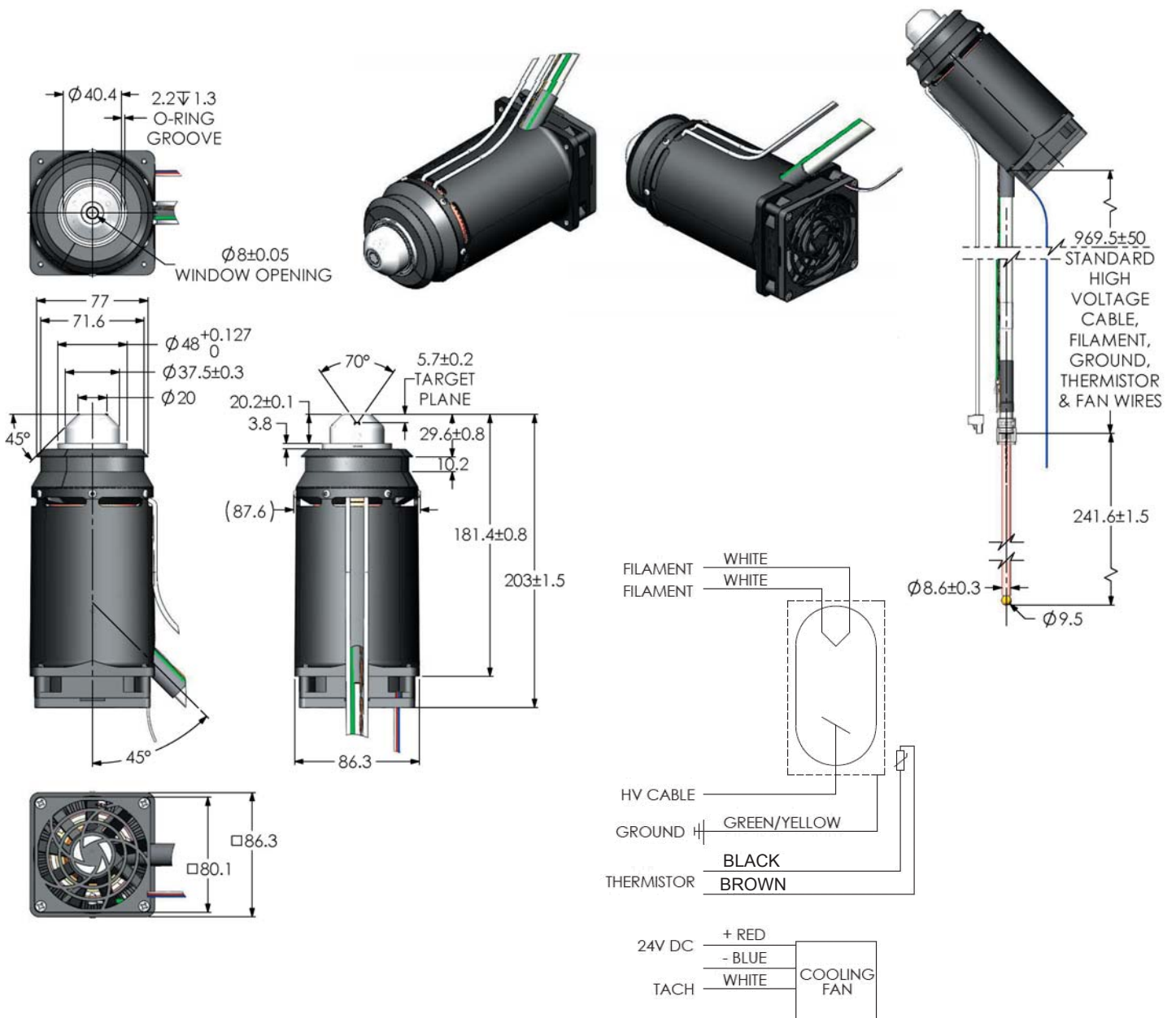

DC EMISSION CHART  
± .05 Amps

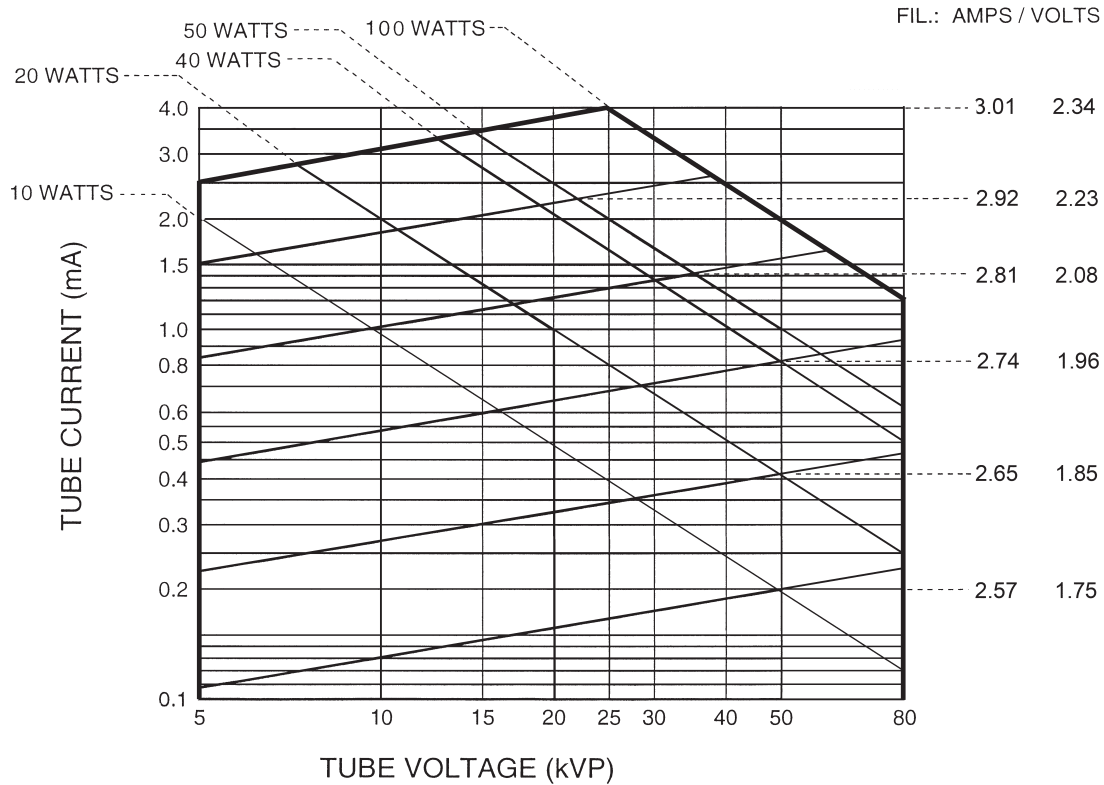

**Warning**

Beryllium windows transmit a very high level of long wavelength X-radiation, which can injure human tissue. Injury may occur from even very short exposures to the primary X-ray beam. Follow all precautions necessary to avoid radiation exposure to humans.

The radiation dose rate cannot be accurately measured with conventional radiation measurement instruments. Radiation intensity in each installation will vary, and calibration must include the effects of long wavelength X-radiation.

Fumes from beryllium metal (or its compounds) as well as dust can be hazardous if inhaled. During use, corrosion products may occur on the beryllium window, but these should not be scraped off, machined, or otherwise removed. Tube unit disposal should conform to federal, state, and local regulations governing beryllium.